

VISION
Rechargeable Products
Lead-Acid Battery

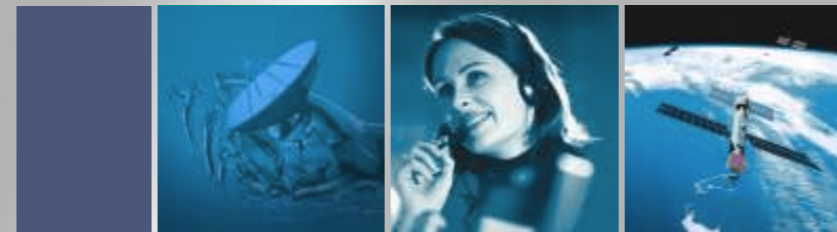

www.vision-batt.com



CT-CFR Series Front Terminal Type Products Guide

One of the largest Sealed Lead Acid Battery manufacturers in the world



Center Power Industrial Park, Tongfu Industrial District, Dapeng Town, PC. 518120, Shenzhen, China
Tel: +86-755-8431 8088 Fax: +86-755-8431 8700
E-mail: sales@vision-batt.com Website: <http://www.vision-batt.com>

(Edition Jan 2009)

Shenzhen Center Power Tech. Co., Ltd

Contents

Introduction	1
Features and benefits	
Standards	
Applications	
Range Summary	
Position of terminals	3
Constraction	4
Performance Data	5-8
Technology	9
Operating Characteristics	10
Operating Instructions and Guidelines	11
Installation and Commissioning Charge	12
Battery Storage	13
Battery Accommodation	14

Introduction

The new VISION CT-CFR series of VRLA batteries has been specially designed for use in telecom systems. With proven compliance to the most rigorous international standards, Such as IEC60896-21/22, BS6290-4, Eurobat Guide, VISION CT-CFR series batteries are recognized as the best ones for telecom applications. With front access terminals, it's easy for installing and taking voltage readings during service. The battery cover made from V0 class flame retardant ABS & with thick walls, offer the battery with high mechanical strength and safety service features. VISION CT-CFR delivers high performance while occupying less space than conventional battery series.

Shenzhen Center Power Tech Co.,Ltd has more than 15 year's experience in the manufacturing of VRLA batteries.

This product guide covers the VISION CT-CFR Front Terminal series and is designed to help users select the appropriate battery for particular applications. Technical information includes detailed discharge performance data for each unit and advice on calculating the correct battery size.

The new VISION CT-CFR Front Terminal range of valve regulated lead acid batteries has been designed specifically for use in applications where demand the highest levels of security and reliability. With proven compliance to international standards, VISION CT-CFR is recognized as one of the best battery series for Telecom/IT applications.

The adoption of gas recombination technology enables lead acid batteries be manufactured in sealed design and maintenance-free. This Technology provides the user with the freedom to use lead acid batteries in a wide range of applications and batteries can be installed in any locations.

The VISION CT-CFR Front Terminal batteries are suitable for 19", 23", and ETSI racking, give users the benefit of increased energy density. With all electrical connections at the front, installation and inspection are simpler and quicker.

Features and benefits



- Thick pasted plates with high quality lead-tin-calcium alloy grids for long service life;
- Centralized venting system for gas ventilation;
- Rope handles for handing and installation convenience;
- Design life 12+ years;

- Easy installation
- Robust copper terminals providing high conductivity, easy connection;
- Front access terminals for easy and quick connection

Applications

- Communication equipment,
- Uninterruptible power supplies;
- Telecommunication systems;
- Electronic cash registers;
- Microprocessor based office machines;
- Other standby power supplies

Standards

- IEC60896-21/22
- BS6290-4
- Eurobat Guide
- IEC 707 FV0
- DOT 167



CT-CFR Range Summary

TYPE	Nominal Voltage(V)	Capacity to 1.8Vpc@10hr,25°C	L(mm)	L(Inch)	W(mm)	W(Inch)	H(mm)	H(Inch)	TH(mm)	TH(Inch)	Terminal	Wt.(Kg)	Wt.(lbs)
CT12-50X-CFR	12	50	277	10.9	106	4.17	222	8.74	229	9.02	M6	17.3	38.1
CT12-80X-CFR	12	80	564	22.2	115	4.53	189	7.44	189	7.44	M8	28.2	62.2
CT12-100X-CFR	12	100	508	20.0	110	4.33	223	8.78	238	9.37	M6	32.5	71.6
CT12-105X-CFR	12	105	395	15.6	110	4.33	286	11.3	293	11.5	M8	35.0	77.2
CT12-125X-CFR	12	125	436	17.2	108	4.25	317	12.5	317	12.5	M8	41.0	90.4
CT12-140X-CFR	12	140	552	21.7	110	4.33	288	11.3	295	11.6	M8	49.0	108
CT12-150X-CFR	12	150	561	22.1	105	4.13	316	12.4	316	12.4	M8	50.4	111
CT12-180X-CFR	12	180	546	21.5	125	4.92	317	12.5	323	12.7	M8	60.0	132



CT12-50X-CFR



CT12-80X-CFR



CT12-100X-CFR



CT12-105X-CFR



CT12-125X-CFR



CT12-140X-CFR



CT12-150X-CFR



CT12-180X-CFR

Position of terminals

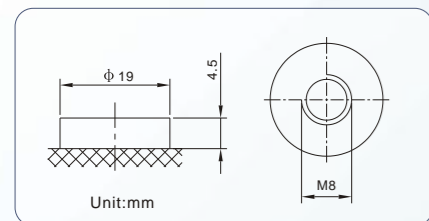

Construction

1. Heavy duty plates

Heavier and thicker plates are pasted from both sides for added durability and a twelve-year design life. Scientific grids designed to resist corrosion and prolong life, special positive grid alloy with pure lead, low calcium and high tin delivers quick high-rate power. Balanced negative plates ensure optimum recombination efficiency.

Tank formed plates ensure full and uniform plate formation optimizing cell voltage balance and performance.

2. Advanced Absorbed Glass Mat (AGM) technology.

Utilizes special micro-porous separators to absorb all the electrolyte lowering internal resistance, increasing power, maximizing space utilization and eliminating leaks for safe installation and storage.

Puncture resistant glass mat separators lowers internal resistance for superior high-rate power while protecting against failures and shorts for maximum life.

3. High conductivity connectors and terminal

Tin plated, copper threaded insert posts, for easy installation and maintenance ensuring the highest current-carrying capacities. Strong copper threaded insert terminals providing high conductivity and power. The front mounted terminal minimises installation work and makes maintenance very convenient during service.

4. High reliable terminal sealing

Epoxy post seal design eliminates post leaks extending battery life and protecting

sophisticated electronic equipment. A proven technology that is 100% factory tested to ensure long life and performance.

5. Tough flame retardant cell box

Thick-wall reinforced flame retardant (RATED UL94, V0 28% LOI) ABS resists bulging and meets safety requirements, highly resistant to shock and vibration. Special reinforced design protects battery while providing added heat dissipation capabilities.

6. Self-regulating relief valve

Low pressure self-return EPDM Rubber valve prevents ingress of atmospheric oxygen, maximizes gas recombination efficiency and minimizes gassing. Self-sealing valves are 100% factory tested to prevent premature dry-out for dependable battery service. Flame arrestors are installed on all flame-retardant batteries for added safety.

7. Lifting handles

All the batteries in the range are provided with rope handles.

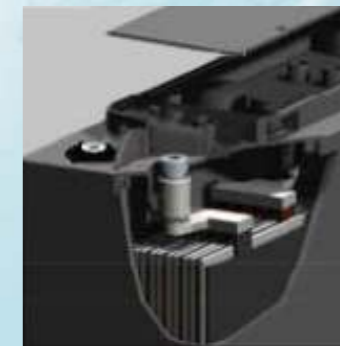

Performance Data

Constant Current Discharge performance

Amperes

Constant Current Discharge (Amperes) at 20°C to 1.60 volts per cell																								
Battery Type	10min	15min	20min	25min	30min	35min	40min	45min	50min	55min	1h	1.5h	2h	2.5h	3h	4h	5h	6h	7h	8h	9h	10h	12h	24h
CT12-50X-CFR	109	88.2	72.9	63.7	57.6	51.8	47.4	44.0	40.5	37.6	35.2	24.9	19.7	16.6	14.5	11.2	9.26	7.85	6.85	6.10	5.51	5.04	4.35	2.27
CT12-80X-CFR	174	141	117	102	92.1	82.8	75.8	70.4	64.8	60.1	56.3	39.8	31.5	26.5	23.2	18.0	14.8	12.6	11.0	9.75	8.82	8.07	6.97	3.63
CT12-100X-CFR	218	176	146	127	115	103	94.8	88.0	81.0	75.2	70.4	49.8	39.4	33.2	29.1	22.5	18.5	15.7	13.7	12.2	11.0	10.1	8.72	4.55
CT12-105X-CFR	229	185	153	134	121	109	99.6	92.4	85.0	78.9	73.9	52.2	41.4	34.8	30.5	23.6	19.4	16.5	14.4	12.8	11.6	10.6	9.15	4.77
CT12-125X-CFR	255	211	175	153	138	123	112	103	95.8	89.9	85.0	60.1	47.7	40.2	35.2	27.9	23.5	20.0	17.4	15.6	14.1	12.9	11.1	5.81
CT12-140X-CFR	305	257	210	181	162	144	130.5	120	110	101	94.4	66.9	53.1	44.8	39.3	31.3	26.5	22.5	19.6	17.4	15.7	14.4	12.4	6.48
CT12-150X-CFR		270	224	196	178	160	147.3	137	127	118	111	79.1	63.1	53.5	47.1	36.5	30.2	25.3	21.7	19.1	17.0	15.4	13.3	6.93
CT12-180X-CFR		300	249	218	197	175	158	145	134	125	118	84.5	67.8	57.7	51.3	39.8	33	28.1	24.7	22.1	20.0	18.4	15.9	8.28

Constant Current Discharge (Amperes) at 20°C to 1.65 volts per cell																								
Battery Type	10min	15min	20min	25min	30min	35min	40min	45min	50min	55min	1h	1.5h	2h	2.5h	3h	4h	5h	6h	7h	8h	9h	10h	12h	24h
CT12-50X-CFR	101	82.7	69.1	60.9	55.5	50.0	45.9	42.7	39.4	36.7	34.5	24.4	19.4	16.3	14.3	11.1	9.19	7.80	6.81	6.07	5.49	5.03	4.34	2.26
CT12-80X-CFR	161	133	111	98	88.7	80.0	73.4	68.3	63.1	58.8	55.2	39.1	31.0	26.1	22.9	17.8	14.7	12.5	10.9	9.71	8.79	8.05	6.95	3.62
CT12-100X-CFR	201	165	138	122	111	100	91.8	85.4	78.8	73.5	69	48.8	38.7	32.6	28.6	22.2	18.4	15.6	13.7	12.2	11.0	10.1	8.72	4.55
CT12-105X-CFR	212	174	146	128	117	105	96.5	89.7	82.8	77.1	72.4	51.3	40.7	34.3	30.1	23.4	19.3	16.4	14.3	12.8	11.6	10.6	9.15	4.77
CT12-125X-CFR	237	200	167	147	134	120	109	101	94.1	88.5	83.8	59.4	47.1	39.8	34.9	27.7	23.3	19.8	17.3	15.4	14.0	12.8	11.1	5.76
CT12-140X-CFR	280	239	198	173	156	139	127	117	107	99.3	92.6	65.8	52.3	44.3	38.9	31.1	26.4	22.4	19.5	17.3	15.6	14.3	12.3	6.44
CT12-150X-CFR		252	212	187	171	155	143	133	123	116	109	77.6	61.9	52.5	46.2	35.8	29.6	24.8	21.4	18.9	16.9	15.3	13.2	6.89
CT12-180X-CFR		285	239	211	192	171	155	143	132	123	116	83.2	66.7	56.9	50.3	39.4	32.8	28.0	24.5	21.9	19.9	18.3	15.8	8.24

(Note) The above characteristics data are average values obtained within three charge/discharge cycles not the minimum values.

Constant Current Discharge (Amperes) at 20°C to 1.70 volts per cell																								
Battery Type	10min	15min	20min	25min	30min	35min	40min	45min	50min	55min	1h	1.5h	2h	2.5h	3h	4h	5h	6h	7h	8h	9h	10h	12h	24h
CT12-50X-CFR	93	77.1	65	58	53.3	48	44.4	41.4	38.4	35.9	33.8	24.0	19.0	16.1	14.1	11.0	9.13	7.76	6.78	6.05	5.48	5.02	4.33	2.26
CT12-80X-CFR	149	123	104	93	85.2	77.1	71.0	66.3	61.4	57.4	54	38.3	30.5	25.7	22.6	17.6	14.6	12.4	10.9	9.68	8.77	8.04	6.94	3.62
CT12-100X-CFR	185	154	131	116	107	96.6	88.9	82.8	76.7	71.7	67.6	47.9	38.1	32.1	28.2	22.0	18.3	15.5	13.6	12.1	10.9	10.0	8.63	4.50
CT12-105X-CFR	195	162	137	122	112	101	93.3	87.0	80.6	75.3	71	50	39.9	33.7	29.6	23.1	19.2	16.3	14.2	12.7	11.5	10.5	9.07	4.73
CT12-125X-CFR	219	188	160	142	131	117	107	99	92	87	83	59	46.6	39.4	34.6	27.5	23.2	19.7	17.2	15.3	13.9	12.7	11.0	5.72
CT12-140X-CFR	254	221	186	164	150	134	122	113	104	97	91	65	51.6	43.8	38.6	30.9	26.3	22.3	19.4	17.2	15.5	14.2	12.3	6.39
CT12-150X-CFR		233	199	178	164	149	138	129	120	112	106	76	60.5	51.4	45.3	35.1	29	24.4	21.1	18.7	16.7	15.2	13.1	6.84
CT12-180X-CFR		269	228	203	187	167	152	140	130	121	114	82	65.6	56.0	49.5	38.9	32.6	27.8	24.4	21.8	19.8	18.2	15.7	8.19

Constant Current Discharge (Amperes) at 20°C to 1.75 volts per cell																								
Battery Type	10min	15min	20min	25min	30min	35min	40min	45min	50min	55min	1h	1.5h	2h	2.5h	3h	4h	5h	6h	7h	8h	9h	10h	12h	24h
CT12-50X-CFR	85	71.6	61	55	51.2	46	42.9	40.1	37.3	35.0	33.1	23.5	18.6	15.7	13.8	10.8	9.06	7.71	6.75	6.02	5.46	5.01	4.33	2.25
CT12-80X-CFR	136	115	98	88	81.6	74.1	68.6	64.2	59.7	56.0	52.9	37.6	29.9	25.3	22.2	17.4	14.5	12.3	10.8	9.64	8.74	8.02	6.92	3.61
CT12-100X-CFR	169	143	123	110	102	92.7	85.7	80.2	74.6	69.9	66.1	46.9	37.3	31.5	27.7	21.7	18.1	15.4	13.5	12.0	10.9	10.0	8.63	4.50
CT12-105X-CFR	178	151	130	117	108	97.8	90.2	84.2	78.3	73.4	69	49	39.3	33.2	29.2	22.8	19	16.2	14.1	12.6	11.4	10.5	9.07	4.73
CT12-125X-CFR	201	177	152	137	127	114	105	97	91	86	81	58	46.1	39.0	34.3	27.2	23	19.5	17.1	15.2	13.8	12.6	10.9	5.67
CT12-140X-CFR	229	203	173	155	143	129	118	110	102	95	89	64	51.0	43.4	38.3	30.7	26.1	22.1	19.2	17.1	15.4	14.1	12.2	6.35
CT12-150X-CFR	235	214	186	168	157	143	133	125	116	109	103	74	59.1	50.3	44.4	34.4	28.4	24.0	20.8	18.4	16.6	15.1	13.0	6.80
CT12-180X-CFR	285	254	218	196	181	163	149	138	127	118	111	80	64.4	55.0	48.8	38.5	32.3	27.6	24.2	21.7	19.7	18.1	15.6	8.15

Constant Current Discharge (Amperes) at 20°C to 1.80 volts per cell																								
Battery Type	10min	15min	20min	25min	30min	35min	40min	45min	50min	55min	1h	1.5h	2h	2.5h	3h	4h	5h	6h	7h	8h	9h	10h	12h	24h
CT12-50X-CFR	77.0	66.0	57.5	52.4	49.0	44.6	41.4	38.8	36.2	34.1	32.4	23.0	18.3	15.5	13.6	10.7	9.00	7.67	6.71	6.00	5.44	5.00	4.32	2.25
CT12-80X-CFR	122	105	92	83	78.1	71.2	66.1	62.1	58.0	55	51.8	36.8	29.3	24.8	21.8	17.2	14.4	12.3	10.7	9.60	8.71	8.00	6.91	3.60
CT12-100X-CFR	153	132	115	105	98	89.3	82.7	77.6	72.4	68	64.7	46.0	36.7	31.0	27.3	21.5	18	15.3	13.4	12.0	10.9	10.0	8.63	4.50
CT12-105X-CFR	161	139	122	111	104	94.4	87.1	81.5	76.1	71.6	67.9	48.3	38.5	32.6	28.7	22.6	18.9	16.1	14.1	12.6	11.4	10.5	9.07	4.73
CT12-125X-CFR	183	165	144	131	123	111	102	95	89	84.1	80.0	57.0	45.5	38.6	34	27.0	22.8	19.4	16.9	15.1	13.6	12.5	10.8	5.63
CT12-140X-CFR	203	185	161	147	137	124	114	106	98	92.2	87.0	62.5	50.3	42.9	38	30.5	26	22.0	19.1	17.0	15.3	14.0	12.1	6.30
CT12-150X-CFR	210	195	172	158	149	137	127	120	112	105	100	71.7	57.5	49.1	43.4	33.7	27.8	23.5	20.5	18.2	16.4	15.0	13.0	6.75
CT12-180X-CFR	261	238	207	188	176	158	145	135	125	116	109	78.5	63.3	54.1	48	38.1	32.1	27.4	24.0	21.5	19.6	18.0	15.5	8.10

(Note) The above characteristics data are average values obtained within three charge/discharge cycles not the minimum values.

Performance Data

Constant Power Discharge performance

Watts per cell

Constant Power Discharge (Watts per cell) at 20°C to 1.60 volts per cell																								
Battery Type	10min	15min	20min	25min	30min	35min	40min	45min	50min	55min	1h	1.5h	2h	2.5h	3h	4h	5h	6h	7h	8h	9h	10h	12h	24h
CCT12-50X-CFR	190	159	135	121	111	100	92.0	85.6	79.0	73.5	69	48.9	38.9	32.7	28.5	22.3	18.5	15.6	13.5	11.9	10.7	9.68	8.31	4.27
CT12-80X-CFR	304	255	217	193	178	160	147	137	126	117	110	78.1	62.2	52.2	45.6	35.6	29.6	24.9	21.5	19.0	17.1	15.5	13.3	6.84
CT12-100X-CFR	380	319	271	242	223	201	184	171	158	147	138	97.8	77.7	65.3	57	44.6	37.1	31.2	27.0	23.8	21.4	19.4	16.6	8.56
CT12-105X-CFR	399	335	285	254	234	211	194	180	166	155	145	103	81.6	68.5	59.8	46.7	38.9	32.7	28.3	25.0	22.4	20.4	17.5	8.99
CT12-125X-CFR	450	376	314	277	252	226	207	192	178	167	157	113	90.8	76.0	66.1	52.4	44.2	37.7	33.1	29.6	26.9	24.8	21.3	10.9
CT12-140X-CFR	488	413	343	301	273	246	226	210	194	182	171	124	100	85.1	75.2	59.4	49.9	42.5	37.2	33.2	30.1	27.6	23.7	12.2
CT12-150X-CFR		432	365	325	298	269	247	230	214	201	190	142	118	100	88.1	69.0	57.6	48.3	41.6	36.6	32.7	29.6	25.4	13.1
CT12-180X-CFR		525	443	393	360	323	296	274	254	238	225	164	134	112	98	76.8	64.1	54.5	47.7	42.5	38.5	35.3	30.3	15.6

Constant Power Discharge (Watts per cell) at 20°C to 1.65 volts per cell																								
Battery Type	10min	15min	20min	25min	30min	35min	40min	45min	50min	55min	1h	1.5h	2h	2.5h	3h	4h	5h	6h	7h	8h	9h	10h	12h	24h
CT12-50X-CFR	179	151	129	116	107	96.6	88.8	82.7	76.5	71.4	67.1	48.0	38.4	32.3	28.2	22.1	18.4	15.5	13.4	11.8	10.6	9.66	8.29	4.27
CT12-80X-CFR	287	242	207	185	171	155	143	133	123	114	107	76.7	61.5	51.7	45.2	35.4	29.5	24.8	21.5	19.0	17.0	15.5	13.3	6.83
CT12-100X-CFR	358	303	259	232	214	193	177	165	153	142	134	95.9	76.8	64.6	56.5	44.2	36.8	31.0	26.9	23.7	21.3	19.4	16.6	8.56
CT12-105X-CFR	376	318	271	243	224	203	187	174	161	150	141	101	80.7	67.9	59.3	46.4	38.6	32.5	28.2	24.9	22.4	20.4	17.5	8.99
CT12-125X-CFR	428	361	304	269	246	221	203	188	174	163	154	111	89.3	75.0	65.4	52.0	43.9	37.5	32.9	29.4	26.7	24.6	21.1	10.9
CT12-140X-CFR	464	395	330	291	265	239	220	205	190	178	168	122	98.8	84.0	74.2	58.7	49.4	42.1	36.9	32.9	29.9	27.5	23.6	12.1
CT12-150X-CFR		420	356	318	292	264	243	227	211	199	188	141	117	99.1	87.2	68.4	57.1	47.9	41.3	36.3	32.5	29.4	25.2	13.0
CT12-180X-CFR		503	426	380	349	314	288	268	249	234	221	162	132	111	97	76.1	63.6	54.1	47.3	42.3	38.3	35.1	30.2	15.5

(Note) The above characteristics data are average values obtained within three charge/discharge cycles not the minimum values.

Constant Power Discharge (Watts per cell) at 20°C to 1.70 volts per cell																								
Battery Type	10min	15min	20min	25min	30min	35min	40min	45min	50min	55min	1h	1.5h	2h	2.5h	3h	4h	5h	6h	7h	8h	9h	10h	12h	24h
CT12-50X-CFR	168	143	123	110	102	92.5	85.4	79.8	74	69.3	65.3	47.0	37.9	32.0	28	21.9	18.2	15.3	13.3	11.8	10.6	9.64	8.27	4.26
CT12-80X-CFR	269	230	197	177	164	149	137	128	118	111	104	75.1	60.7	51.2	44.8	35.1	29.2	24.6	21.3	18.9	17.0	15.4	13.2	6.82
CT12-100X-CFR	337	286	246	221	205	186	171	160	148	139	131	94.3	75.9	64.0	56	43.8	36.5	30.7	26.6	23.5	21.1	19.2	16.5	8.48
CT12-105X-CFR	354	301	258	232	215	195	180	168	156	145	137	98.8	79.7	67.1	58.7	46.0	38.3	32.3	27.9	24.7	22.2	20.2	17.3	8.90
CT12-125X-CFR	406	347	293	261	239	215	198	184	170	159	150	109	87.9	74.0	64.7	51.5	43.6	37.2	32.6	29.2	26.5	24.4	20.9	10.8
CT12-140X-CFR	441	377	318	282	258	233	215	200	186	175	165	120	97.5	83.0	73.3	58.1	49	41.8	36.6	32.7	29.7	27.3	23.4	12.0
CT12-150X-CFR		407	347	310	286	259	239	223	208	196	186	139	116	98.2	86.3	67.7	56.5	47.4	40.9	36.0	32.2	29.2	25.0	12.9
CT12-180X-CFR		480	410	367	339	306	281	262	244	229	217	159	130	110	96	75.4	63.1	53.7	47.0	42.0	38.1	34.9	30.0	15.4

Constant Power Discharge (Watts per cell) at 20°C to 1.75 volts per cell																								
Battery Type	10min	15min	20min	25min	30min	35min	40min	45min	50min	55min	1h	1.5h	2h	2.5h	3h	4h	5h	6h	7h	8h	9h	10h	12h	24h
CT12-50X-CFR	158	135	116	105	97.9	88.9	82.2	76.9	71.5	67.2	63.5	46.2	37.5	31.6	27.7	21.7	18.1	15.3	13.3	11.7	10.6	9.62	8.26	4.25
CT12-80X-CFR	252	216	186	168	156	142	131	123	115	108	102	74	60.0	50.6	44.3	34.7	29.0	24.5	21.2	18.8	16.9	15.4	13.2	6.80
CT12-100X-CFR	316	270	233	211	196	178	165	154	143	134	127	92.3	75.0	63.2	55.4	43.4	36.2	30.5	26.5	23.5	21.1	19.2	16.5	8.48
CT12-105X-CFR	331	284	245	222	206	187	173	162	150	141	133	96.8	78.7	66.4	58.2	45.6	38.0	32.1	27.8	24.6	22.1	20.2	17.3	8.90
CT12-125X-CFR	383	333	283	252	232	209	192	179	166	156	147	107	86.4	72.9	63.9	51.0	43.2	36.9	32.3	28.9	26.3	24.2	20.8	10.7
CT12-140X-CFR	418	358	304	272	250	226	208	194	181	171	162	118	96.3	81.9	72.3	57.4	48.5	41.4	36.3	32.4	29.5	27.1	23.2	12.0
CT12-150X-CFR	440	394	337	303	280	254	234	219	205	194	184	138	115	97.2	85.3	66.9	55.9	46.9	40.5	35.7	32.0	29.0	24.9	12.8
CT12-180X-CFR	517	458	393	354	328	298	275	257	239	224	212	155	127	108	95.0	74.7	62.5	53.3	46.6	41.7	37.8	34.8	29.8	15.3

Constant Power Discharge (Watts per cell) at 20°C to 1.80 volts per cell																								
Battery Type	10min	15min	20min	25min	30min	35min	40min	45min	50min	55min	1h	1.5h	2h	2.5h	3h	4h	5h	6h	7h	8h	9h	10h	12h	24h
CT12-50X-CFR	147	127	110	100	93.4	85.1	78.9	74.1	69.1	65.1	61.7	45.2	37.0	31.3	27.5	21.5	17.9	15.1	13.2	11.7	10.5	9.60	8.24	4.24
CT12-80X-CFR	235	203	177	161	150	137	127	119	111	104	98.8	72.5	59.3	50.1	44.0	34.4	28.7	24.3	21.1	18.7	16.8	15.4	13.2	6.78
CT12-100X-CFR	294	254	221	200	187	170	158	148	138	130	123	90.4	74.1	62.6	54.9	43.0	35.9	30.3	26.4	23.4	21.1	19.2	16.5	8.48
CT12-105X-CFR	309	267	232	210	196	179	166	156	146	137	130	95.2	77.8	65.7	57.7	45.2	37.7	31.9	27.7	24.5	22.1	20.2	17.3	8.90
CT12-125X-CFR	361	318	272	244	225	204	188	175	163	152	144	105	85.0	71.9	63.2	50.5	42.9	36.6	32.1	28.7	26.1	24.0	20.6	10.6
CT12-140X-CFR	395	340	291	262	242	219	202	189	177	167	159	116	95.0	80.8	71.3	56.7	48.0	41.0	35.9	32.2	29.2	26.9	23.1	11.9
CT12-150X-CFR	420	381	327	295	273	248	230	215	201	190	181	136	113	95.8	84.3	66.2	55.3	46.5	40.2	35.4	31.7	28.8	24.7	12.7
CT12-180X-CFR	492	435	377	341	318	289	268	251	234	220	208	153	125	106	94.0	74.0	62.0	52.9	46.3	41.4	37.6	34.6	29.7	15.3

(Note) The above characteristics data are average values obtained within three charge/discharge cycles not the minimum values.

Technology

Principle of VRLA batteries

During charging of conventional lead acid battery, electrolysis of water occurs at the final stage, then (so) hydrogen generates from the negative plates and oxygen from the positive plates. This causes water loss and periodic watering is needed.

However, evolution of oxygen and hydrogen gases does not occur simultaneously, because the recharge of the positive plates is not as efficient as the negative ones. This means that oxygen is evolved from the positive plate before hydrogen is evolved from the negative plate.

At the same time that oxygen is evolved from the positive plate, a substantial amount of highly active spongy lead exists on the negative plate before it commences hydrogen evolution. Therefore, providing oxygen can be transported to the negative plates, conditions are ideal for a rapid reaction between lead and oxygen, i.e. oxygen is electrochemically reduced on the negative plate according to the following formula,

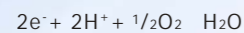

and the final product is water.

The current flowing through the negative plate drives this reaction instead of hydrogen evolution which occur in a conventional battery.

This process is called gas recombination. If this process is 100% efficient no water would be lost from the battery. By careful design and selection of battery components, gas recombination efficiency is between 95% to 99%.

Principle of the oxygen reduction cycle

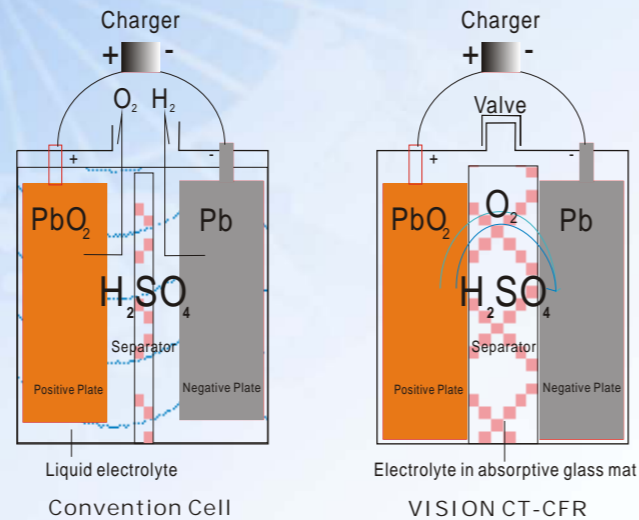

Conventional Cell

Oxygen and hydrogen escape to the atmosphere.

VISION CT-CFR

Oxygen from the positive plate transfers to the negative and recombines with lead to form water.

Recombination efficiency

Recombination efficiency is determined under specific conditions by measuring the volume of hydrogen emitted from the battery and converting this into its ampere hour equivalent. This equivalent value is then subtracted from the total ampere hours taken by the battery during the test period, and the remainder is the battery's recombination efficiency and is usually expressed as a percentage.

As recombination is never 100%, some hydrogen gas is emitted from batteries through the safety valve. The volume of gas emitted is very small and typical average values on constant potential float at 20°C are as follows:

VISION CT-CFR hydrogen emissions	
Float Voltage (V)	Volume of gas emitted (ml per cell per C ₁₀ Ah per month)
13.5~13.8	3.8
14.4~14.7	25

Operating Characteristics



The VISION CT-CFR Front Terminal units should be charged using constant potential chargers.

Float voltage

At normal room temperature (20°C), the recommended float voltage is equal to 2.25 volts per cell.

To optimise battery performance it is recommended that the float voltage is adjusted for room ambient temperatures in accordance with the following table.

Temperature	Float voltage range per cell
0°C	2.31-2.36V
10°C	2.28-2.33V
20°C	2.25-2.30V
25°C	2.23-2.28V
30°C	2.22-2.27V
35°C	2.20-2.25V
40°C	2.19-2.24V

Under these conditions a recharge will be completed in approximately 72 hours.

Charging current

A discharged VRLA battery will accept a high recharge current, but for those seeking a more economical charging system a current limit of 0.3 C₁₀ (A) is adequate.

Note: For a completely discharged battery, 80% of the capacity is replaced in approximately:

- 10 hours at 0.1 C₁₀
- 6 hours at 0.3 C₁₀
- 5 hours no current limit applied

Fast recharge

Increasing the charge voltage to 14.4~14.7volts per battery can reduce recharge time and it is possible, depending on the depth of discharge, to halve the recharge time. Under these conditions, however, the charge must be monitored and must be terminated when the charge current remains reasonably steady for 3 consecutive hours after the voltage limit has been reached. At the beginning of charge the current must be limited to 0.3 C₁₀ (A). This charge regime, in order to achieve a normal service life, must not be used more than once per month

The effect of temperature on capacity

Correction factors for capacity at different temperatures are shown in the following table, the reference temperature being 20°C.

Duration of discharge	Battery temperature											
	-15°C	-10°C	-5°C	0°C	5°C	10°C	15°C	20°C	25°C	30°C	35°C	40°C
15min	0.50	0.56	0.63	0.70	0.77	0.84	0.92	1.00	1.08	1.16	1.24	1.31
1 hour	0.62	0.67	0.73	0.78	0.84	0.89	0.95	1.00	1.05	1.10	1.15	1.20
10hour	0.73	0.77	0.81	0.85	0.89	0.93	0.96	1.00	1.03	1.06	1.09	1.11



www.vision-batt.com
Communication Batteries

Operating Instructions and Guidelines

Accidental deep discharge

- e.g. (I) Discharge at a lower current for a longer time than the original system specification.
 (II) Failure of the charging system.
 (III) Battery not recharged immediately after a discharge.

When a battery is completely discharged:

- (I) The utilisation of the sulphuric acid in the electrolyte is total and the electrolyte now consists only of water. During recharge this condition may produce metallic dendrites which can penetrate the separator and cause a short circuit in a cell.
 (II) The sulphation of the plate is at its maximum and the internal resistance of the cell is also at its maximum.

The battery should be recharged under a constant potential of 2.28 volts per cell with the current limited to a maximum of 0.3 C₁₀(A) in order to prevent excessive internal heating. For instance, for a CT12-155X-CFR the maximum charge current is 46.5 amps. If the sulphation of the cell/battery is extensive, then the recharge of the battery may require more than 96 hours.

Note: Deep discharging will produce a premature deterioration of the battery and a noticeable reduction in the life expectancy of the battery.

For optimum operation the minimum voltage of the system should be related to the duty as follows:

Duty	Minimum end voltage
t < 1h	1.65V
1 h < t ≤ 5h	1.70V
5 h < t < 8h	1.75V
8 h < t ≤ 20h	1.80V

In order to protect the battery it is advisable to have system monitoring and low voltage cut-out.

Float charge ripple

Excessive ripple on the D.C. supply across a battery has the effect of reducing life and performance.

It is recommended therefore, that voltage regulation across the system including the load, but without the battery connected, under steady state conditions, shall be better than ±1% between 5% and 100% load.

Transient and other ripple type excursions can be accommodated provided that, with the battery disconnected but the load connected, the system peak to peak voltage including the regulation limits, falls within ±2.5% of the recommended float voltage of the battery.

Under no circumstances should the current flowing through the battery when it is operating under float conditions, reverse into the discharge mode.

Electro-Magnetic Compatibility (EMC)

VISION CT-CFR products are covered by the EMC statement in prEN 50226:1995 which reads as follows:

Rechargeable cells or batteries are not sensitive to normal electromagnetic disturbances, and therefore no immunity tests shall be required. Free-standing rechargeable cells or batteries electrically isolated from any associated electrical system are for all practical purposes electromagnetically inert, and therefore the requirements for electromagnetic compatibility shall be deemed to be satisfied.

Note: It should be noted that rechargeable cells or batteries are part of an electrical system, and the manner in which they are used could invoke the requirements of the electromagnetic compatibility upon that system. In such cases, the requirements of electromagnetic compatibility shall be accommodated by the design of the system.

Maintenance

- Every month, check that the total voltage at the battery terminals is (N x 2.25V) for a temperature of 20°C.
- N = the number of cells in the battery and 2.25V = 20°C float voltage.
- Once a year, take a reading of the individual bloc voltages in the battery. A variation of ±2.5% on individual voltages from the average voltage is acceptable.
- The system must be checked once or twice a year.

Principal factors affecting the life of recombination batteries

- Deep discharge
- Poor control of the float voltage
- Cycling or micro-cycling
- Poor quality of charging current (excessive ripple)
- High ambient temperature

Installation and Commissioning Charge

Warning

VISION CT-CFR Front Terminal units are already charged when delivered.

They should be unpacked with care. Avoid short circuiting terminals of opposite polarity as these units are capable of discharging at a very high current, especially if the lid or the container is damaged.

Acid leakage and unusual appearance must be avoided before switching on, noting open circuit voltage.

There must be appointed man operating for 24 hs after switching on to solving potential problems in time, noting voltage and current.

Unpacking

It is advisable to unpack all the monoblocs and accessories before commencing to erect and not to unpack and erect monobloc by monobloc.

All items should be carefully checked against the accompanying advice notes to ascertain if any are missing. Advise the Sales Department of any discrepancies.

A rigid plastic insulating cover is provided which totally protects the unit terminals. This is factory fitted to all products of the range and there is no need to remove it until access to the terminals is required.

Setting up the battery stands

The structure should be assembled in accordance with instructions supplied with the equipment.

To level the stand use the adjustable insulating feet.

Mounting in a cabinet

Ensure that the cabinet:

- Is sufficiently strong to cope with the weight of the battery.
- Is suitably insulated
- Is naturally ventilated

Connecting the monoblocs

- Torque setting
Tighten the nuts or bolts to the recommended levels of torque indicated on the product label.

Always use insulated tools for fitting and torquing up battery connections.

- In series**
The number of cells in series (N) will not affect the selected float voltage per cell.
Therefore, charging float voltage = N x Cell float Voltage
No special circuit arrangements are required.
- In parallel**
Using constant voltage chargers, and ensuring that the connections made between the charger and the batteries have the same electrical resistance, no special arrangements have to be made for batteries in parallel. Although no special circuit arrangements are required, where the parallel connection is made at the charger or distribution board, to avoid out of step conditions, the bus bar run length and the area of cross section should be designed so that the circuit resistance value for each string is equal within limits ±5%.
There is no technical reason for limiting the number of strings but for practical installation reasons. It is recommended not allowed to exceed 3 strings in parallel especially if the battery is used in high discharge rates (backup time less than 15 mins)

General recommendations

- Do not wear clothing of synthetic material to avoid static generation.
- Use only a clean soft damp cloth for cleaning the monoblocs. Do not use chemicals or detergents.
- Use insulated tools.
- Commence installation at the least accessible point.
- Consult the drawing for the correct position of the monobloc poles.

Commissioning charge

Ensure that the batteries will be operated in a clean environment.

Before use, the batteries should be charged at a constant float voltage adjusted according to the ambient temperature, e.g. 13.5~13.8V/battery at 20°C for 48 to 96 hours or, alternatively, a voltage of 14.4~14.7V/battery at 20°C can be used to reduce the commissioning period from 24 to 15 hours.

Where the batteries have been stored under harsh conditions, this increased voltage recharge is particularly effective.

Battery Storage

Storage conditions

Store the battery in a dry, clean and preferably cool location.

Storage time

As the batteries are supplied charged, storage time is limited. In order to easily charge the batteries after prolonged storage, it is advisable not to store batteries for more than:

- 6 months at 20°C
- 3 months at 30°C
- 6 weeks at 40°C

Battery state of charge

The battery state of charge can be determined by measuring the open-circuit voltage of cells in rest position for 24 hours at 20°C.

State of charge	Voltage
100%	2.14Vpc
80%	2.10Vpc
60%	2.07Vpc
40%	2.04Vpc
20%	2.00Vpc

Open circuit voltage variation with temperature is 25mV per 10°C.

Recharge of stored batteries

A refreshing charge shall be performed after this time at 13.5-13.8V/ battery at 20°C for 48 to 96 hours.

A current limit is not essential, but for optimum charge efficiency the current output of the charger can be limited to 20% of the 10-hour rated capacity.

The necessity of a refreshing charge can also be determined by measuring the open circuit voltage of a stored battery. Refreshing charge is advised if the voltage drops below 2.10 volts per cell.

Failure to observe these conditions may result in greatly reduced capacity and service life.



Battery Accommodation

The VISION CT-CFR Front Terminal battery's compact design and standard footprint, suitable for 19" 23" and ETSI racking, give users the benefit of increased energy density. With all electrical connections at the front, installation and inspection are simpler and quicker.

