

VISION
Rechargeable Products
Lead-Acid Battery



www.vision-batt.com



CTA-CFR Series

Front Terminal Type
Products Guide

One of the largest Sealed Lead Acid Battery manufacturers in the world



Center Power Industrial Park, Tongfu Industrial District, Dapeng Town, PC. 518120, Shenzhen, China
Tel: +86-755-8431 8088 Fax: +86-755-8431 8700
E-mail: sales@vision-batt.com Website: <http://www.vision-batt.com>

(Edition Jan 2009)

Shenzhen Center Power Tech. Co., Ltd

Contents

Introduction	1
Features and benefits	
Standards	
Construction	2
Range Summary	
Position of terminals	3
Performance Data	4-7
Selection of Battery Size	8
Technology	9
Operating Characteristics	10
Operating Instructions and Guidelines	11
Installation and Commissioning Charge	12
Battery Storage	13
Battery Accommodation	14

Introduction

The new VISION CTR-CFR series of VRLA batteries has been specially designed for use in telecom systems. With proven compliance to the most rigorous international standards, Such as IEC60896-21/22, BS6290-4, Eurobat Guide, VISION CTR-CFR series batteries are recognized as the best ones for telecom applications. With front access terminals, it's easy for installing and taking voltage readings during service. The battery cover made from V0 class flame retardant ABS & with thick walls, offer the battery with high mechanical strength and safety service features. VISION CTR-CFR delivers high performance while occupying less space than conventional battery series. Shenzhen Center Power Tech Co.,Ltd has more than 15 year's experience in the manufacturing of VRLA batteries. This product guide covers the VISION CTR-CFR Front Terminal series and is designed to help users select the appropriate battery for particular applications. Technical information includes detailed discharge performance data for each unit and advice on calculating the correct battery size.

The new VISION CTR-CFR Front Terminal range of valve regulated lead acid

batteries has been designed specifically for use in applications where demand the highest levels of security and reliability. With proven compliance to international standards, VISION CTR-CFR is recognized as one of the best battery series for Telecom/IT applications.

The adoption of gas recombination technology enables lead acid batteries be manufactured in sealed design and maintenance-free. This Technology provides the user with the freedom to use lead acid batteries in a wide range of applications and batteries can be installed in any locations.

The VISION CTR-CFR Front Terminal batteries are suitable for 19", 23", and ETSI racking, give users the benefit of increased energy density. With all electrical connections at the front, installation and inspection are simpler and quicker.

Features and benefits

Thick pasted plates with high quality lead-tin-calcium alloy grids for long service life;
Centralized venting system for gas ventilation;
Rope handles for handling and installation convenience;
Design life 12+ years;

Easy installation
Robust copper terminals providing high conductivity, easy connection;
Front access terminals for easy and quick connection

Construction

1. High conductivity connectors and terminal
Strong copper threaded insert terminals providing high conductivity and power. The front access terminals make installation very convenient.
2. High reliability terminal sealing
VISION's unique construction and sealing technique guarantee that no electrolyte leakage can occur.
3. Self-regulating relief valve
Low-pressure self-return valve prevents ingress of oxygen in the atmosphere.
4. Thick positive plates
Scientific grids designed to resist corrosion and increase battery service life.
5. Balanced negative plates
Ensure optimum recombination efficiency.
6. Tough & V0 flame retardant battery ensure safety operation of battery.
7. Separators
Low resistance microporous glassfibre. The electrolyte is absorbed within this material.
8. Lifting handles
All the batteries in the range are provided with rope handles.

Standards

IEC60896-21/22
BS6290-4
Eurobat Guide
IEC 707 FV0
DOT 167

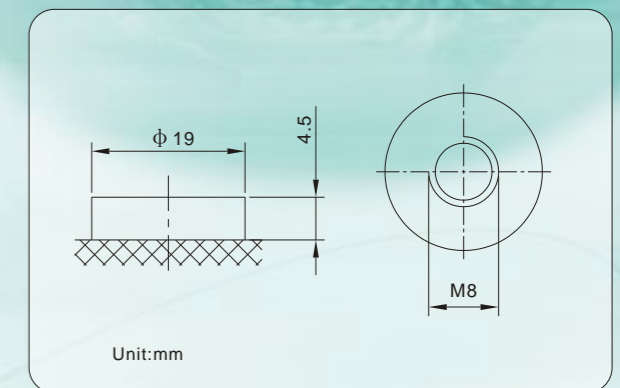

Range Summary

TYPE	Nominal Voltage(V)	Capacity to 1.8Vpc@10hr,20°C	L(mm)	L(Inch)	W(mm)	W(Inch)	H(mm)	H(Inch)	TH(mm)	TH(Inch)	Terminal	Wt. (Kg)	Wt. (lbs)
CTA12-50X-CFR	12	50	279	11.0	105	4.13	280	11.0	280	11.0	M8	20.0	44.1
CTA12-75X-CFR	12	75	563	22.2	115	4.53	188	7.40	188	7.40	M8	28.5	62.8
CTA12-80X-CFR	12	80	508	20.0	110	4.33	231	9.09	231	9.09	M8	31.0	68.4
CTA12-85X-CFR	12	85	393	15.5	125	4.92	256	10.1	256	10.1	M8	32.0	70.6
CTA12-100X-CFR	12	100	558	22.0	125	4.92	228	8.98	228	8.98	M8	40.0	88.2
CTA12-125X-CFR	12	125	561	22.1	105	4.13	316	12.4	316	12.4	M8	49.5	109
CTA12-140X-CFR	12	140	428	16.8	177	6.97	253	9.96	253	9.96	M8	48.6	107
CTA12-155X-CFR	12	155	546	21.5	125	4.92	315	12.4	315	12.4	M8	59.0	130



CTA12-50X-CFR



CTA12-75X-CFR



CTA12-80X-CFR



CTA12-85X-CFR



CTA12-100X-CFR



CTA12-125X-CFR



CTA12-155X-CFR

Position of terminals



Performance Data

Constant Current Discharge performance

Battery Type	Constant Current Discharge (Amperes) at 20°C to 1.60 volts per cell																						
	15min	20min	25min	30min	35min	40min	45min	50min	55min	1h	1.5h	2h	2.5h	3h	4h	5h	6h	7h	8h	9h	10h	12h	24h
CTA12-50X-CFR	104	85.7	72.9	63.2	56.1	50.6	45.6	42.0	38.6	35.8	25.2	20.0	16.8	14.7	11.9	10.0	8.46	7.33	6.48	5.82	5.30	4.57	2.38
CTA12-75X-CFR	155	129	109	94.9	84.2	75.9	68.4	63.0	58.0	53.6	37.8	29.9	25.1	22.0	17.8	15.1	12.7	11.0	9.73	8.74	7.94	6.86	3.57
CTA12-80X-CFR	166	137	117	101	89.8	80.9	73.0	67.2	61.8	57.2	40.3	31.9	26.8	23.4	19.0	16.1	13.5	11.7	10.4	9.32	8.47	7.31	3.81
CTA12-85X-CFR	176	146	124	108	95.4	86.0	77.5	71.4	65.7	60.8	42.8	33.9	28.5	24.9	20.1	17.1	14.4	12.5	11.0	9.90	9.00	7.77	4.05
CTA12-100X-CFR	207	171	146	126	112	101	91.2	84.0	77.3	71.5	50.4	39.9	33.5	29.3	23.7	20.1	16.9	14.7	13.0	11.7	10.6	9.14	4.76
CTA12-125X-CFR	214	182	158	140	126	114	105	96.6	89.4	83.0	63.0	49.9	41.9	36.6	29.6	25.1	21.2	18.3	16.2	14.6	13.2	11.4	5.95
CTA12-140X-CFR	260	215	180	160	140	129	117	108	100	93.5	67.0	53.0	45.5	39.5	31.5	26.5	22.5	20.0	18.0	16.5	14.8	12.8	6.85
CTA12-155X-CFR	213	186	164	147	138	126	116	106	99.5	93.5	67.0	53.0	45.5	39.5	31.5	26.5	22.5	20.0	18.0	16.5	14.8	12.8	6.85

Amperes

Battery Type	Constant Current Discharge (Amperes) at 20°C to 1.65 volts per cell																						
	15min	20min	25min	30min	35min	40min	45min	50min	55min	1h	1.5h	2h	2.5h	3h	4h	5h	6h	7h	8h	9h	10h	12h	24h
CTA12-50X-CFR	96.0	80.9	68.9	60.7	53.3	48.2	43.4	39.8	37.2	35.0	24.7	19.5	16.4	14.4	11.6	9.84	8.30	7.20	6.38	5.74	5.22	4.53	2.36
CTA12-75X-CFR	144	121	103	91.0	80.0	72.3	65.2	59.7	55.8	52.5	37.1	29.3	24.6	21.5	17.4	14.8	12.5	10.8	9.57	8.60	7.84	6.79	3.54
CTA12-80X-CFR	153	129	110	97.1	85.3	77.1	69.5	63.7	59.5	56.0	39.5	31.2	26.2	23.0	18.6	15.7	13.3	11.5	10.2	9.18	8.36	7.24	3.78
CTA12-85X-CFR	163	138	117	103	90.7	81.9	73.9	67.7	63.2	59.5	42.0	33.2	27.9	24.4	19.7	16.7	14.1	12.2	10.8	9.75	8.88	7.69	4.01
CTA12-100X-CFR	192	162	138	121	107	96.4	86.9	79.6	74.4	70.0	49.4	39.0	32.8	28.7	23.2	19.7	16.6	14.4	12.8	11.5	10.5	9.05	4.72
CTA12-125X-CFR	202	172	152	133	120	109	99.5	93.0	87.5	81.5	61.8	48.8	41.0	35.9	29.0	24.6	20.8	18.0	15.9	14.3	13.1	11.3	5.90
CTA12-140X-CFR	245	203	171	153	134	124	113	104	97.1	91.0	65.3	51.7	44.5	38.6	30.9	26.0	22.1	19.7	17.7	16.3	14.6	12.6	6.77
CTA12-155X-CFR	204	177	156	143	133	126	114	106	99.5	93.5	67.0	53.0	45.5	39.5	31.5	26.5	22.5	20.0	18.0	16.5	14.8	12.8	6.85

(Note) The above characteristics data are average values obtained within three charge/discharge cycles not the minimum values.

Constant Current Discharge (Amperes) at 20°C to 1.70 volts per cell																							
Battery Type	15min	20min	25min	30min	35min	40min	45min	50min	55min	1h	1.5h	2h	2.5h	3h	4h	5h	6h	7h	8h	9h	10h	12h	24h
CTA12-50X-CFR	90.8	76.9	65.8	58.0	51.5	46.3	42.0	39.1	36.5	34.3	24.2	19.1	16.1	14.0	11.3	9.62	8.13	7.06	6.27	5.65	5.15	4.47	2.34
CTA12-75X-CFR	136	115	98.6	87.0	77.3	69.5	63.0	58.6	54.7	51.5	36.2	28.7	24.1	21.0	17.0	14.4	12.2	10.6	9.40	8.47	7.73	6.70	3.50
CTA12-80X-CFR	145	123	105	92.8	82.4	74.1	67.2	62.5	58.3	54.9	38.6	30.6	25.7	22.4	18.1	15.4	13.0	11.3	10.0	9.03	8.24	7.15	3.74
CTA12-85X-CFR	154	131	112	98.6	87.6	78.8	71.4	66.4	62.0	58.3	41.1	32.5	27.3	23.8	19.2	16.3	13.8	12.0	10.7	9.60	8.76	7.59	3.97
CTA12-100X-CFR	182	154	132	116	103	92.7	84.0	78.2	72.9	68.6	48.3	38.2	32.1	28.0	22.6	19.2	16.3	14.1	12.5	11.3	10.3	8.93	4.67
CTA12-125X-CFR		192	164	145	129	116	105	97.7	91.1	85.8	60.4	47.8	40.1	35.0	28.3	24.0	20.3	17.7	15.7	14.1	12.9	11.2	5.84
CTA12-140X-CFR	230	192	162	145	128	119	109	101	94.3	88.5	63.6	50.5	43.4	37.8	30.2	25.5	21.7	19.4	17.5	16.0	14.4	12.5	6.70
CTA12-155X-CFR		194	170	151	139	129	121	116	111	80.3	63.0	53.2	46.7	40.7	36.5	30.4	25.4	21.9	19.5	17.4	15.7	13.9	7.33

Constant Current Discharge (Amperes) at 20°C to 1.75 volts per cell																							
Battery Type	15min	20min	25min	30min	35min	40min	45min	50min	55min	1h	1.5h	2h	2.5h	3h	4h	5h	6h	7h	8h	9h	10h	12h	24h
CTA12-50X-CFR	85.5	72.5	62.4	55.7	49.6	44.7	41.0	37.9	35.2	33.0	23.7	18.7	15.7	13.7	11.1	9.37	7.95	6.93	6.17	5.57	5.10	4.41	2.32
CTA12-75X-CFR	128	109	93.6	83.6	74.4	67.1	61.5	56.9	52.9	49.6	35.5	28.1	23.6	20.6	16.7	14.1	11.9	10.4	9.25	8.36	7.65	6.61	3.47
CTA12-80X-CFR	137	116	100	89.1	79.4	71.5	65.6	60.7	56.4	52.9	37.8	29.9	25.1	21.9	17.8	15.0	12.7	11.1	9.90	8.92	8.16	7.05	3.70
CTA12-85X-CFR	145	123	106	94.7	84.3	76.0	69.7	64.5	59.9	56.2	40.2	31.8	26.7	23.3	18.9	15.9	13.5	11.8	10.5	9.48	8.67	7.49	3.94
CTA12-100X-CFR	171	145	125	111	99.2	89.4	82.0	75.9	70.5	66.1	47.3	37.4	31.4	27.4	22.2	18.8	15.9	13.9	12.3	11.2	10.2	8.81	4.63
CTA12-125X-CFR		181	156	139	124	112	103	94.8	88.1	82.6	59.1	46.8	39.3	34.3	27.8	23.4	19.9	17.3	15.4	13.9	12.8	11.0	5.79
CTA12-140X-CFR	215	180	152	138	122	114	104	96.8	91.4	86.0	61.8	49.2	42.4	36.9	29.6	25.0	21.3	19.0	17.2	15.8	14.2	12.3	6.62
CTA12-155X-CFR		185	164	144	135	125	118	112	107	78.9	62.2	52.7	46.3	40.7	36.2	30.2	25.3	21.8	19.3	17.3	15.6	13.8	7.28

Constant Current Discharge (Amperes) at 20°C to 1.80 volts per cell																							
Battery Type	15min	20min	25min	30min	35min	40min	45min	50min	55min	1h	1.5h	2h	2.5h	3h	4h	5h	6h	7h	8h	9h	10h	12h	24h
CTA12-50X	82.0	69.0	60.3	53.9	48.4	43.7	40.0	37.0	34.4	32.1	23.2	18.3	15.4	13.5	10.9	9.14	7.76	6.77	6.04	5.46	5.00	4.32	2.27
CTA12-75X	123	104	90.4	80.9	72.5	65.5	60.0	55.5	51.5	48.2	34.8	27.5	23.1	20.2	16.4	13.7	11.6	10.2	9.05	8.19	7.50	6.49	3.41
CTA12-80X	131	110	96.0	86.3	77.4	69.8	64.0	59.2	55.0	51.4	37.1	29.3	24.6	21.5	17.4	14.6	12.4	10.8	9.70	8.74	8.00	6.92	3.63
CTA12-85X	139	117	102	91.7	82.2	74.2	68.0	62.9	58.4	54.6	39.4	31.1	26.2	22.9	18.5	15.5	13.2	11.5	10.3	9.28	8.50	7.35	3.86
CTA12-100X	164	138	120	108	96.7	87.3	80.0	74.0	68.7	64.3	46.4	36.6	30.8	26.9	21.8	18.3	15.5	13.6	12.1	10.9	10.0	8.65	4.54
CTA12-125X		173	151	135	121	109	100	92.5	85.9	80.3	58.0	45.8	38.5	33.6	27.3	22.9	19.4	16.9	15.1	13.7	12.5	10.8	5.68
CTA12-140X	200	168	143	130	116	109	100	93.1	88.5	83.5	60.1	47.9	41.3	36.0	29.0	24.5	20.9	18.7	16.9	15.5	14.0	12.1	6.54
CTA12-155X		173	151	138	127	119	114	107	102	77.0	61.5	52.2	46.0	40.7	36.0	30.0	25.1	21.6	19.2	17.2	15.5	13.7	7.23

(Note)The above characteristics data are average values obtained within three charge/discharge cycles not the minimum values.

Performance Data

Constant Power Discharge performance

Watts per cell

Constant Power Discharge (Watts per cell) at 20°C to 1.60 volts per cell																							
Battery Type	15min	20min	25min	30min	35min	40min	45min	50min	55min	1h	1.5h	2h	2.5h	3h	4h	5h	6h	7h	8h	9h	10h	12h	24h
CTA12-50X-CFR	177	148	126	111	99.3	90.6	82.8	76.7	71.4	66.5	47.0	37.1	31.3	27.5	22.3	19.2	16.3	14.0	12.6	11.3	10.2	8.75	4.50
CTA12-75X-CFR	266	222	189	167	149	136	124	115	107	99.8	70.5	55.6	47.0	41.3	33.5	28.7	24.4	21.0	18.8	16.9	15.3	13.1	6.74
CTA12-80X-CFR	284	237	202	178	159	145	132	123	114	106	75.2	59.3	50.1	44.0	35.7	30.6	26.1	22.4	20.1	18.0	16.3	14.0	7.19
CTA12-85X-CFR	302	252	214	189	169	154	141	130	121	113	79.9	63.0	53.3	46.8	37.9	32.6	27.7	23.8	21.3	19.1	17.3	14.9	7.64
CTA12-100X-CFR	355	296	252	223	199	181	166	154	143	133	94.0	74.1	62.7	55.0	44.6	38.3	32.6	28.0	25.1	22.5	20.4	17.5	8.99
CTA12-125X-CFR		356	302	267	238	217	199	184	179	166	117	92.7	78.3	68.8	55.8	47.9	40.7	35.0	31.4	28.1	25.5	21.9	11.2
CTA12-140X-CFR	470	390	328	292	257	237	216	200	186	175	126	100	86.0	75.0	60.2	51.0	43.5	38.8	35.0	32.2	29.0	25.1	13.8
CTA12-155X-CFR		358	320	290	266	249	235	224	212	155	125	107	95.1	84.4	74.4	62.0	52.2	45.2	41.0	36.8	33.4	28.9	14.9

Constant Power Discharge (Watts per cell) at 20°C to 1.65 volts per cell																							
Battery Type	15min	20min	25min	30min	35min	40min	45min	50min	55min	1h	1.5h	2h	2.5h	3h	4h	5h	6h	7h	8h	9h	10h	12h	24h
CTA12-50X-CFR	168	141	122	108	96.2	87.5	79.2	74.0	69.0	64.4	45.8	36.0	30.7	27.1	22.0	18.8	16.0	13.8	12.4	11.2	10.1	8.70	4.48
CTA12-75X-CFR	252	212	183	161	144	131	119	111	104	96.6	68.7	53.9	46.0	40.7	33.0	28.3	23.9	20.6	18.6	16.7	15.2	13.1	6.71
CTA12-80X-CFR	269	226	195	172	154	140	127	118	110	103	73.3	57.5	49.0	43.4	35.2	30.1	25.5	22.0	19.8	17.8	16.2	13.9	7.16
CTA12-85X-CFR	285	240	207	183	163	149	135	126	117	110	77.9	61.1	52.1	46.1	37.4	32.0	27.1	23.4	21.1	19.0	17.2	14.8	7.61
CTA12-100X-CFR	336	282	244	215	192	175	158	148	138	129	91.6	71.9	61.3	54.2	44.0	37.7	31.9	27.5	24.8	22.3	20.2	17.4	8.95
CTA12-125X-CFR		338	293	258	231	210	190	177	173	161	115	89.9	76.6	67.8	55.0	47.1	39.9	34.4	31.0	27.9	25.3	21.8	11.2
CTA12-140X-CFR	444	369	312	279	247	228	209	194	181	171	123	97.9	84.3	73.6	59.3	50.3	42.9	38.4	34.6	31.9	28.8	24.9	13.7
CTA12-155X-CFR		346	308	282	259	244	230	219	209	153	123	106	94.4	84.4	73.8	61.5	51.7	44.8	40.6	36.5	33.1	28.6	14.8

(Note)The above characteristics data are average values obtained within three charge/discharge cycles not the minimum values.

Battery Type	Constant Power Discharge (Watts per cell) at 20°C to 1.70 volts per cell																						
	15min	20min	25min	30min	35min	40min	45min	50min	55min	1h	1.5h	2h	2.5h	3h	4h	5h	6h	7h	8h	9h	10h	12h	24h
CTA12-50X-CFR	159	133	115	103	92.3	84.7	77.1	71.8	67.3	63.5	45.1	35.4	30.2	26.7	21.7	18.4	15.7	13.6	12.4	11.1	10.1	8.69	4.45
CTA12-75X-CFR	238	200	173	154	138	127	116	108	101	95.3	67.7	53.1	45.3	40.1	32.5	27.6	23.6	20.4	18.5	16.6	15.1	13.0	6.68
CTA12-80X-CFR	254	213	185	164	148	136	123	115	108	102	72.2	56.6	48.3	42.7	34.6	29.5	25.1	21.8	19.8	17.7	16.1	13.9	7.12
CTA12-85X-CFR	270	226	196	174	157	144	131	122	114	108	76.7	60.2	51.3	45.4	36.8	31.3	26.7	23.1	21.0	18.8	17.1	14.8	7.57
CTA12-100X	318	266	231	205	184	169	154	144	135	127	90.2	70.8	60.4	53.4	43.3	36.8	31.4	27.2	24.7	22.1	20.1	17.4	8.90
CTA12-125X		319	277	246	221	203	185	172	168	159	113	88.5	75.5	66.8	54.1	46.0	39.3	34.0	30.9	27.6	25.1	21.7	11.1
CTA12-140X	418	349	296	266	236	220	201	188	177	167	120	95.8	82.5	72.2	58.4	49.5	42.3	37.9	34.3	31.6	28.5	24.7	13.6
CTA12-155X			337	301	273	252	238	225	215	204	151	105	93.7	82.5	73.3	61.0	51.3	44.4	40.4	36.2	32.9	28.4	14.7

Battery Type	Constant Power Discharge (Watts per cell) at 20°C to 1.75 volts per cell																						
	15min	20min	25min	30min	35min	40min	45min	50min	55min	1h	1.5h	2h	2.5h	3h	4h	5h	6h	7h	8h	9h	10h	12h	24h
CTA12-50X-CFR	149	126	111	99.0	88.5	81.1	75.7	69.8	66.1	61.8	44.2	34.9	29.7	26.3	21.4	18.2	15.5	13.4	12.3	11.0	10.0	8.65	4.43
CTA12-75X-CFR	223	189	166	148	133	122	114	105	99.0	92.7	66.2	52.3	44.6	39.5	32.0	27.4	23.3	20.1	18.4	16.5	15.0	13.0	6.65
CTA12-80X-CFR	238	201	177	158	142	130	121	112	106	99.0	70.6	55.8	47.5	42.1	34.2	29.2	24.8	21.4	19.6	17.6	16.0	13.8	7.09
CTA12-85X-CFR	253	214	189	168	150	138	129	119	112	105	75.1	59.2	50.5	44.7	36.3	31.0	26.4	22.8	20.8	18.7	17.0	14.7	7.53
CTA12-100X-CFR	298	252	222	198	177	162	151	140	132	124	88.3	69.7	59.4	52.6	42.7	36.5	31.0	26.8	24.5	22.0	20.0	17.3	8.86
CTA12-125X-CFR		302	266	237	212	195	182	168	165	154	110	87.1	74.3	65.8	53.4	45.6	38.8	33.5	30.6	27.5	25.0	21.6	11.1
CTA12-140X-CFR	391	328	279	253	226	211	194	181	172	162	117	93.6	80.8	70.8	57.4	48.8	41.6	37.5	33.9	31.2	28.3	24.5	13.5
CTA12-155X-CFR			326	293	267	248	232	221	211	200	149	104	92.5	82.5	72.7	60.5	50.9	44.1	40.0	35.9	32.6	28.2	14.6

Battery Type	Constant Power Discharge (Watts per cell) at 20°C to 1.80 volts per cell																						
	15min	20min	25min	30min	35min	40min	45min	50min	55min	1h	1.5h	2h	2.5h	3h	4h	5h	6h	7h	8h	9h	10h	12h	24h
CTA12-50X-CFR	137	118	104	94.0	85.3	78.3	73.3	68.4	64.1	60.1	43.2	34.3	29.3	25.9	21.1	17.9	15.3	13.3	12.1	10.9	9.84	8.50	4.41
CTA12-75X-CFR	206	177	155	141	128	118	110	103	96.2	90.2	64.9	51.5	43.9	38.8	31.6	26.9	23.0	19.9	18.1	16.3	14.8	12.8	6.61
CTA12-80X-CFR	220	189	166	151	136	125	117	109	103	96.0	69.2	54.9	46.8	41.4	33.7	28.7	24.5	21.2	19.3	17.4	15.7	13.6	7.05
CTA12-85X-CFR	234	201	176	160	145	133	125	116	109	102	73.5	58.3	49.7	43.9	35.8	30.5	26.0	22.5	20.5	18.5	16.7	14.5	7.49
CTA12-100X-CFR	275	237	207	188	171	157	147	137	128	120	86.5	68.6	58.5	51.7	42.1	35.9	30.6	26.5	24.1	21.8	19.7	17.0	8.81
CTA12-125X-CFR		284	248	226	205	188	176	164	160	150	108	85.8	73.1	64.6	52.6	44.9	38.3	33.1	30.1	27.2	24.6	21.3	11.0
CTA12-140X-CFR	365	307	263	240	215	202	186	175	167	158	114	91.5	79.0	69.4	56.5	48.0	41.0	37.0	33.5	30.9	28.0	24.3	13.4
CTA12-155X-CFR			313	282	261	242	229	217	206	196	147	118	103	91.0	72.1	60.0	50.5	43.7	39.7	35.6	32.4	28.0	14.5

(Note) The above characteristics data are average values obtained within three charge/discharge cycles not the minimum values.

Selection of battery size

The following examples are designed to illustrate the method of determining which VISION CTR-CFR Front Terminal unit will support your required duty load.

Constant current discharge
EXAMPLE A. To demonstrate constant current calculation and also the effect of temperature.

A nominal 50V telecommunications system using a 24 cell battery and requiring 18.5 amps constant current will operate satisfactorily at a minimum battery terminal volts level of 42 volts.

Calculate the battery type required for 5 hours standby duration on the basis of:

- (a) 20°C operating temperature
- (b) 0°C operating temperature

METHOD

- (1) Minimum allowable volts per cell

$$\frac{42 \text{ volts}}{24 \text{ cells}} = 1.75\text{Vpc}$$

- (2) Hence, cell performance requirement is 18.5 amps Constant current to 1.75Vpc

- (3) By reference to constant current performance table relating to 1.75 volts per cell level (see page 5):

(a) at 20°C
CTA12-100X-CFR unit size is smallest available size to use (18.8 amps available).
Conclusion: Use 4 - CTA12-100X-CFR.

(b) at 0°C
By reference to the table on page 10 of this product guide, available current output at 0°C is reduced by factor 0.83.

The refore at 0°C- 5 hours output is reduced to, on CTA12-100X-CFR size, 18.8 amps x 0.83 = 15.8 amps.

Hence CTA12-100X-CFR unit size too small!
Try the next largest unit size - CTA12-125X-CFR. At 0°C available current output is 23.4 amps x 0.83 = 19.4 amps.

Conclusion: Use 4 - CTA12-125X-CFR.

Constant power discharge
EXAMPLE B. To demonstrate constant power calculation.

An inverter system requires a D.C. constant power input of 5.8 kW in the voltage range 451 volts maximum, 317 volts minimum.

Calculate the optimum battery size required for 20°C operation for a 4 hour standby period.

METHOD

- (1) Number of cells
= 451/2.28Vpc = 198 cells.
- (2) Minimum volt per cell
317/198 = 1.6Vpc.
- (3) Watts per cell
= 5800 watts / 198 cells = 29.3watts per cell.
- (4) Hence cell performance requirement is 29.3 watts to 1.6Vpc at 20°C.
- (5) By reference to the constant power performance table (see page 6) relating to 1.6 volts per cell level, CTA12-75X-CFR monobloc is the correct available size to use.

Principle of VRLA batteries

During charging of conventional lead acid battery, electrolysis of water occurs at the final stage, then (so) hydrogen generates from the negative plates and oxygen from the positive plates. This causes water loss and periodic watering is needed.

However, evolution of oxygen and hydrogen gases does not occur simultaneously, because the recharge of the positive plates is not as efficient as the negative ones. This means that oxygen is evolved from the positive plate before hydrogen is evolved from the negative plate.

At the same time that oxygen is evolved from the positive plate, a substantial amount of highly active spongy lead exists on the negative plate before it commences hydrogen evolution. Therefore, providing oxygen can be transported to the negative plates, conditions are ideal for a rapid reaction between lead and oxygen, i.e. oxygen is electrochemically reduced on the negative plate according to the following formula,

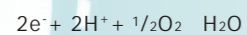

and the final product is water.

The current flowing through the negative plate drives this reaction instead of hydrogen evolution which occur in a conventional battery.

This process is called gas recombination. If this process is 100% efficient no water would be lost from the battery. By careful design and selection of battery components, gas recombination efficiency is between 95% to 99%.

Principle of the oxygen reduction cycle

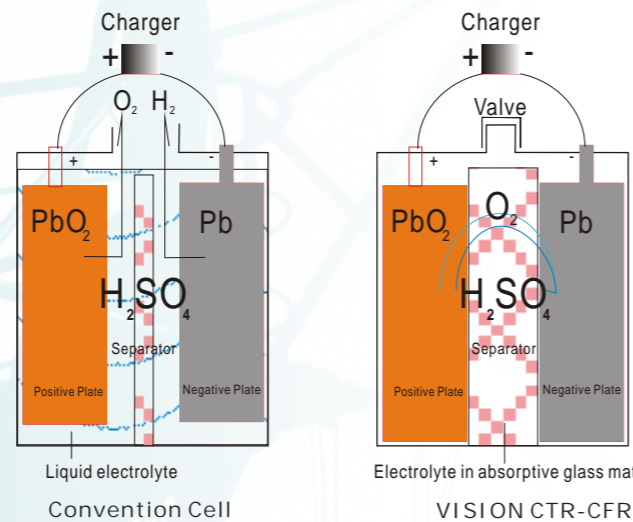

Conventional Cell

Oxygen and hydrogen escape to the atmosphere.

VISION CTR-CFR

Oxygen from the positive plate transfers to the negative and recombines with lead to form water.

Recombination efficiency

Recombination efficiency is determined under specific conditions by measuring the volume of hydrogen emitted from the battery and converting this into its ampere hour equivalent. This equivalent value is then subtracted from the total ampere hours taken by the battery during the test period, and the remainder is the battery's recombination efficiency and is usually expressed as a percentage.

As recombination is never 100%, some hydrogen gas is emitted from batteries through the safety valve. The volume of gas emitted is very small and typical average values on constant potential float at 20°C are as follows:

VISION CTR-CFR hydrogen emissions	
Float Voltage (V)	Volume of gas emitted (ml per cell per C ₁₀ Ah per month)
13.5~13.8	3.8
14.4~14.7	25

The VISION CTR-CFR Front Terminal units should be charged using constant potential chargers.

Float voltage

At normal room temperature (20°C), the recommended float voltage is equal to 2.25 volts per cell.

To optimise battery performance it is recommended that the float voltage is adjusted for room ambient temperatures in accordance with the following table.

Temperature	Float voltage range per cell
0°C	2.31-2.36V
10°C	2.28-2.33V
20°C	2.25-2.30V
25°C	2.23-2.28V
30°C	2.22-2.27V
35°C	2.20-2.25V
40°C	2.19-2.24V

Under these conditions a recharge will be completed in approximately 72 hours.

Charging current

A discharged VRLA battery will accept a high recharge current, but for those seeking a more economical charging system a current limit of 0.3 C₁₀ (A) is adequate.

Note: For a completely discharged battery, 80% of the capacity is replaced in approximately:

- 10 hours at 0.1 C₁₀
- 6 hours at 0.3 C₁₀
- 5 hours no current limit applied

Fast recharge

Increasing the charge voltage to 14.4~14.7volts per battery can reduce recharge time and it is possible, depending on the depth of discharge, to halve the recharge time. Under these conditions, however, the charge must be monitored and must be terminated when the charge current remains reasonably steady for 3 consecutive hours after the voltage limit has been reached. At the beginning of charge the current must be limited to 0.3 C₁₀ (A). This charge regime, in order to achieve a normal service life, must not be used more than once per month

The effect of temperature on capacity

Correction factors for capacity at different temperatures are shown in the following table, the reference temperature being 20°C.

Duration of discharge	Battery temperature											
	-15°C	-10°C	-5°C	0°C	5°C	10°C	15°C	20°C	25°C	30°C	35°C	40°C
15min	0.50	0.56	0.63	0.70	0.77	0.84	0.92	1.00	1.08	1.16	1.24	1.31
1 hour	0.62	0.67	0.73	0.78	0.84	0.89	0.95	1.00	1.05	1.10	1.15	1.20
10hour	0.73	0.77	0.81	0.85	0.89	0.93	0.96	1.00	1.03	1.06	1.09	1.11

Operating Instructions and Guidelines

Accidental deep discharge

- e.g. (I) Discharge at a lower current for a longer time than the original system specification.
- (II) Failure of the charging system.
- (III) Battery not recharged immediately after a discharge.

When a battery is completely discharged:

- (I) The utilisation of the sulphuric acid in the electrolyte is total and the electrolyte now consists only of water. During recharge this condition may produce metallic dendrites which can penetrate the separator and cause a short circuit in a cell.
- (II) The sulphation of the plate is at its maximum and the internal resistance of the cell is also at its maximum.

The battery should be recharged under a constant potential of 2.28 volts per cell with the current limited to a maximum of 0.3 C₁₀(A) in order to prevent excessive internal heating. For instance, for a CTA12-155X-CFR the maximum charge current is 46.5 amps. If the sulphation of the cell/battery is extensive, then the recharge of the battery may require more than 96 hours.

Note: Deep discharging will produce a premature deterioration of the battery and a noticeable reduction in the life expectancy of the battery.

For optimum operation the minimum voltage of the system should be related to the duty as follows:

Duty	Minimum end voltage
t < 1h	1.65V
1 h < t ≤ 5h	1.70V
5 h < t < 8h	1.75V
8 h < t ≤ 20h	1.80V

In order to protect the battery it is advisable to have system monitoring and low voltage cut-out.

Float charge ripple

Excessive ripple on the D.C. supply across a battery has the effect of reducing life and performance.

It is recommended therefore, that voltage regulation across the system including the load, but without the battery connected, under steady state conditions, shall be better than ±1% between 5% and 100% load.

Transient and other ripple type excursions can be accommodated provided that, with the battery disconnected but the load connected, the system peak to peak voltage including the regulation limits, falls within ±2.5% of the recommended float voltage of the battery.

Under no circumstances should the current flowing through the battery when it is operating under float conditions, reverse into the discharge mode.

Electro-Magnetic Compatibility (EMC)

VISION CTR-CFR products are covered by the EMC statement in prEN 50226:1995 which reads as follows:

Rechargeable cells or batteries are not sensitive to normal electromagnetic disturbances, and therefore no immunity tests shall be required. Free-standing rechargeable cells or batteries electrically isolated from any associated electrical system are for all practical purposes electromagnetically inert, and therefore the requirements for electromagnetic compatibility shall be deemed to be satisfied.

Note: It should be noted that rechargeable cells or batteries are part of an electrical system, and the manner in which they are used could invoke the requirements of the electromagnetic compatibility upon that system. In such cases, the requirements of electromagnetic compatibility shall be accommodated by the design of the system.

Maintenance

- Every month, check that the total voltage at the battery terminals is (N x 2.25V) for a temperature of 20°C.
- N = the number of cells in the battery and 2.25V = 20°C float voltage.
- Once a year, take a reading of the individual bloc voltages in the battery. A variation of ±2.5% on individual voltages from the average voltage is acceptable.
- The system must be checked once or twice a year.

Principal factors affecting the life of recombination batteries

- Deep discharge
- Poor control of the float voltage
- Cycling or micro-cycling
- Poor quality of charging current (excessive ripple)
- High ambient temperature

Installation and Commissioning Charge

Warning

VISION CTR-CFR Front Terminal units are already charged when delivered.

They should be unpacked with care. Avoid short circuiting terminals of opposite polarity as these units are capable of discharging at a very high current, especially if the lid or the container is damaged.

Acid leakage and unusual appearance must be avoided before switching on, noting open circuit voltage.

There must be appointed man operating for 24 hs after switching on to solving potential problems in time, noting voltage and current.

Unpacking

It is advisable to unpack all the monoblocs and accessories before commencing to erect and not to unpack and erect monobloc by monobloc.

All items should be carefully checked against the accompanying advice notes to ascertain if any are missing. Advise the Sales Department of any discrepancies.

A rigid plastic insulating cover is provided which totally protects the unit terminals. This is factory fitted to all products of the range and there is no need to remove it until access to the terminals is required.

Setting up the battery stands

The structure should be assembled in accordance with instructions supplied with the equipment.

To level the stand use the adjustable insulating feet.

Mounting in a cabinet

Ensure that the cabinet:

- Is sufficiently strong to cope with the weight of the battery.
- Is suitably insulated
- Is naturally ventilated

Connecting the monoblocs

- Torque setting
Tighten the nuts or bolts to the recommended levels of torque indicated on the product label.

Always use insulated tools for fitting and torquing up battery connections.

- In series**
The number of cells in series (N) will not affect the selected float voltage per cell.
Therefore, charging float voltage = N x Cell float Voltage
No special circuit arrangements are required.
- In parallel**
Using constant voltage chargers, and ensuring that the connections made between the charger and the batteries have the same electrical resistance, no special arrangements have to be made for batteries in parallel. Although no special circuit arrangements are required, where the parallel connection is made at the charger or distribution board, to avoid out of step conditions, the bus bar run length and the area of cross section should be designed so that the circuit resistance value for each string is equal within limits ±5%.
There is no technical reason for limiting the number of strings but for practical installation reasons. It is recommended not allowed to exceed 3 strings in parallel especially if the battery is used in high discharge rates (backup time less than 15 mins)

General recommendations

- Do not wear clothing of synthetic material to avoid static generation.
- Use only a clean soft damp cloth for cleaning the monoblocs. Do not use chemicals or detergents.
- Use insulated tools.
- Commence installation at the least accessible point.
- Consult the drawing for the correct position of the monobloc poles.

Commissioning charge

Ensure that the batteries will be operated in a clean environment.

Before use, the batteries should be charged at a constant float voltage adjusted according to the ambient temperature, e.g. 13.5 ~ 13.8V/battery at 20°C for 48 to 96 hours or, alternatively, a voltage of 14.4 ~ 14.7V/battery at 20°C can be used to reduce the commissioning period from 24 to 15 hours.

Where the batteries have been stored under harsh conditions, this increased voltage recharge is particularly effective.

Battery Storage

Storage conditions

Store the battery in a dry, clean and preferably cool location.

Storage time

As the batteries are supplied charged, storage time is limited.

In order to easily charge the batteries after prolonged storage, it is advisable not to store batteries for more than:

- 6 months at 20°C
- 3 months at 30°C
- 6 weeks at 40°C

Battery state of charge

The battery state of charge can be determined by measuring the open-circuit voltage of cells in rest position for 24 hours at 20°C.

State of charge	Voltage
100%	2.14Vpc
80%	2.10Vpc
60%	2.07Vpc
40%	2.04Vpc
20%	2.00Vpc

Open circuit voltage variation with temperature is 25mV per 10°C.

Recharge of stored batteries

A refreshing charge shall be performed after this time at 13.5-13.8V/ battery at 20°C for 48 to 96 hours.

A current limit is not essential, but for optimum charge efficiency the current output of the charger can be limited to 20% of the 10-hour rated capacity.

The necessity of a refreshing charge can also be determined by measuring the open circuit voltage of a stored battery. Refreshing charge is advised if the voltage drops below 2.10 volts per cell.

Failure to observe these conditions may result in greatly reduced capacity and service life.



Battery Accommodation

The VISION Front Terminal battery's compact design and standard footprint, suitable for 19" 23" and ETSI racking, give users the benefit of increased energy density.

With all electrical connections at the front, installation and inspection are simpler and quicker.

